



N201

Features

- Microprocessor based numerical relay
- Current measurement based on fundamental frequency
- Low-set definite time relay
- High-set instantaneous relay
- Separate low-set and high-set indicators
- Option to disable the high-set element
- Front panel access to the test function
- Complies with IEC 60255 standard
- ANSI Code : 50N, 51N

Technical Data

RATINGS

Auxiliary Supply

Model N201-240AD

Rated voltage	: 100 ~ 240 V AC or 140 ~ 340 V DC
Operating voltage	: 85 ~ 265 V AC or 110 ~ 370 V DC
Rated frequency	: 50 or 60 Hz
Power consumption	: <3 VA max

Current Inputs

Rated current, I _n , I _{0n}	: 5 A
Frequency	: 50 or 60 Hz nominal
Burden	: < 0.3 VA
Thermal withstand	: 4 x I _n continuous

Output Contacts

Trip Contact Relay R1, R2

Rated voltage	: 250 V AC / DC
Continuous carry	: 5 A
Expected electrical life	: 100,000 operations at rated load
Expected mechanical life:	5 x 10 ⁶ operations

SETTING RANGES

Low-set (I _{>})	: 0.1 to 2.0 A
	: 2% to 40%
Low-set delay time (DELAY)	: 0.05 to 1.0 sec
High-set (I _{>>})	: I _{>} to 10 x I _{>} or disable
High-set delay time (t _{>>})	: Instantaneous

ACCURACY

Protection thresholds	: ± 5%
Time delay	: ± 5% with a minimum of 50ms

INDICATORS

Auxiliary supply	: Green indicator
Pick-up	: Red indicator
Trip	: Red indicator

ENVIRONMENTAL CONDITIONS

Temperature	: -10°C to 55°C
Humidity	: 5% to 95%, non-condensing

MECHANICAL

Mounting	: Panel mounting
Dimension (mm)	: 72(w) x 72(h) x 97(d)
Enclosure protection	: IP40 at the panel
Approximate weight	: 0.3k g

Typical Application Diagram

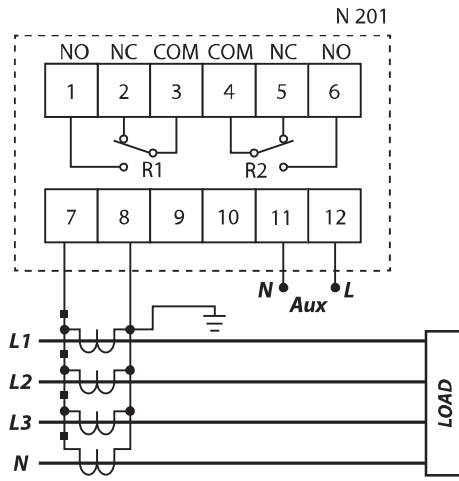

Ordering Information

MODEL	DESCRIPTION
N201 - 240AD	For 50 Hz system, auxiliary voltage 85~265 V AC / 110~370 V DC
N201 - 240AD	For 60 Hz system, auxiliary voltage 85~265 V AC / 110~370 V DC

Case Dimensions

